



## AXIAL EXTRACT FANS

### APPLICATION

Ideal for air-extraction in bathroom, toilet and small/medium premises.  
Suitable to extract stale air directly to the outside or through short length ducting. Units can be wall/panel, ceiling and window mounted.

### SPECIFICATION

**Casing** made of high quality ABS provides long lasting shock-proof and robust construction. The unit is finished in white RAL 9010 and are UV resistant.

**Unique design winglet-type impeller**, providing enhanced aerodynamic properties, low noise and increased efficiency.

**Single-phase induction motors** with integral thermal protection, mounted on sealed for life high quality sleeve bearings.  
Suitable for continuous and intermittent running.

### FEATURES & BENEFITS

**IPX4** protection degree.

**Stylish bright finishing of the front cover** to meet any modern interior design requirement.

**Aerodynamic-shaped inlet and front deflectors** to optimize the efficiency and the acoustic comfort.

**Rigid optimised spigot support** preventing distortion with strengthened guard and design to maximise airflow.

**Integral back-draught shutter** to prevent air flowing back into the room when the fan is off.

**Low power consumption:** 100mm model has less than 8 watts operating power consumption for energy saving.

**Totally recyclable plastic components**, environmentally friendly.

**Double insulated:** no earth connection is required.

**Tested to the latest standards:** units are tested in the TÜV Rheinland recognised laboratory at Aeraulika, meaning accurate, up to date information on electrical safety, performance and noise level that can be relied upon. Designed and manufactured in accordance with EN60335-2-80 (Low Voltage Directive) and the EMC Directive (Electromagnetic Compatibility).

### VERSIONS

#### Standard

The fan is operated via a separate ON/OFF switch or the light switch.

#### Run-on timer

The fan is equipped with a timer circuit adjustable from  $\pm 1'$  to  $25'$ .  
Operation: after switching off, the fan continues to run for the pre-set period of time.

#### Humidistat & timer

The fan is provided with an electronic circuit having a humidity sensor on board (adjustable from 50% to 95% RH) and a timer, adjustable from  $\pm 1'$  to  $25'$ .  
Operation: when the percentage of relative humidity is higher/lower than the pre-set threshold, the fan is automatically activated/deactivated. After switching off, the fan continues to run for the pre-set period of time.

### OPTIONS

**Ball bearing motor** type to assure a longer fan life (30.000h): ideal for cold climates.

**Different voltage and frequency** motors can be offered to meet specific needs.

## Installation

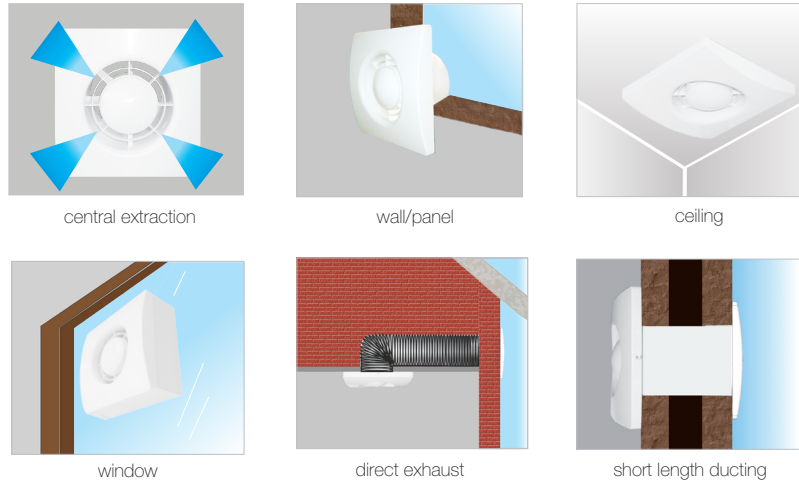

## Dimensions (mm) and Weight (kg)

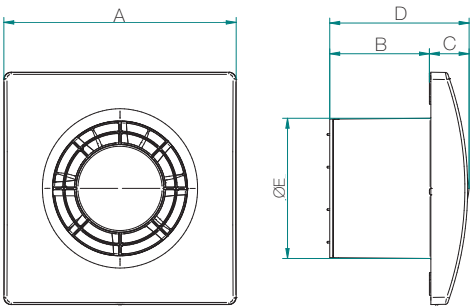

Model	QS90	QS100	QS120	QS150
A	164	164	184	218
B	55	70	81	97
C	28	28	27	27
D	83	98	108	124
ØE	90	99	119	148
Weight	0,5	0,6	0,7	1,2

## Performance curve

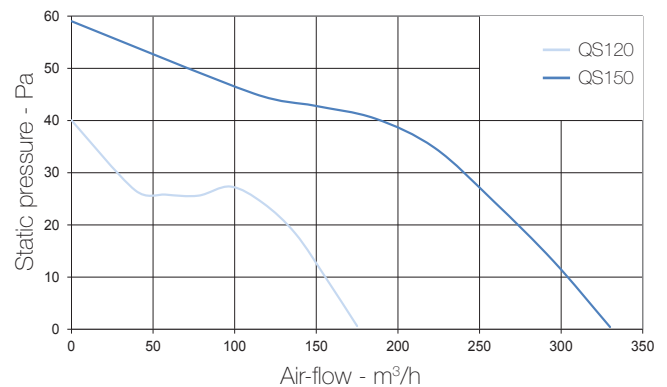
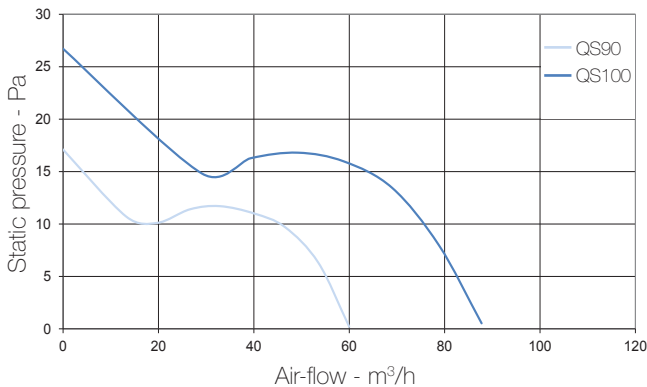

## Performances

Model	QS90	QS100	QS120	QS150
Air-flow m <sup>3</sup> /h max	60	88	175	330
Static pressure Pa max	17	27	40	59
Power consumption W max	8	8	14	24
Sound pressure dB(A) @ 3m <sup>(1)</sup>	26	26	33	42
Ambient temperature °C max	50	50	50	50
Marking/Mark	CE	CE	CE	CE

- 220-240V ~ 50/60Hz.
- air performance measured according to ISO 5801 a 230V 50Hz, air density 1,2Kg/m<sup>3</sup>.
- data measured in the TÜV Rheinland recognised laboratory in Aerauliga.
- (1) sound pressure level @ 3m in free field, for comparative purposes only.

